

| REV | ECO | DESCRIPTION | DATE | BY | APP |
|-----|------|------------------------|----------|----|-----|
| B | 3281 | CHANGE WASHER / REDRAW | 8/5/2009 | GL | JK |

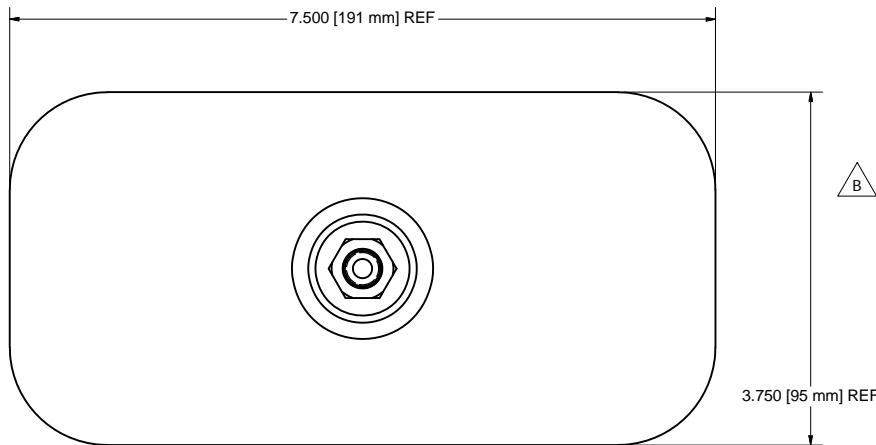
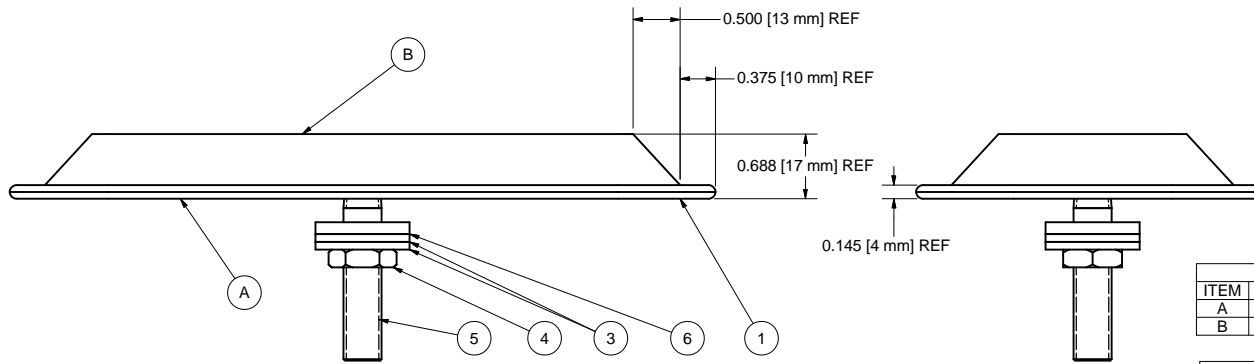
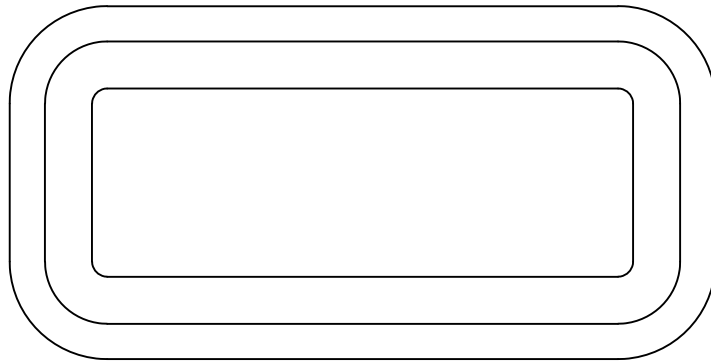

NOTES:

DIFFUSER EDGES MUST BE HELD BY BODY CRIMPING OPERATION TO PREVENT ANY DIFFUSER MOVEMENT IN AERATOR BODY.

| SUB ASSEMBLY COMPONENTS: 20160060 | | | | |
|-----------------------------------|----------|----------|--------------------------------|-----|
| ITEM | PART | DWG | DESCRIPTION | QTY |
| A | 20160061 | B0160017 | BODY BRACKET ASSEMBLY PLATED | 1 |
| B | 20160043 | B0160019 | FIBERGLASS GALVANIZED DIFFUSER | 1 |

| SUB ASSEMBLY COMPONENTS: 20160059 | | | | |
|-----------------------------------|----------|----------|------------------------------|-----|
| ITEM | PART | DWG | DESCRIPTION | QTY |
| A | 20160061 | B0160017 | BODY BRACKET ASSEMBLY PLATED | 1 |
| B | 20160042 | B0160019 | COTTON GALVANIZED DIFFUSER | 1 |

| PARTS LIST | | | | |
|------------|----------|----------|--|-----|
| ITEM | PART# | DWG | DESCRIPTION | QTY |
| 1 | 20160060 | | OPTIONAL: FG AERATOR - BODY & DIFFUSER - CLOSED - PLATED W/ FIBERGLASS | 1 |
| | 20160059 | | CG AERATOR - BODY & DIFFUSER - CLOSED - PLATED W/ COTTON | |
| 2 | 20160019 | A0160027 | Label AD Aerator A009RFBK | 1 |
| 3 | AD-9S | | Stainless steel spacer washer | 2 |
| 4 | AD-6 | A0160015 | Brass locknut. | 1 |
| 5 | AD-5 | A0160004 | Brass tank nipple. | 1 |
| 6 | AD-10 | A0160004 | 1/8" neoprene gasket. | 1 |

MODEL AD-C: COTTON CLOTH DIFFUSER
MODEL AD-F: FIBERGLASS CLOTH DIFFUSER

HARDWARE PACKAGED UN-ASSEMBLED.

| | | | |
|---|------------------------|--|--------------|
| DRAWN RM | 8/22/1983 |  Conveyor Components Company 130 Seltzer Road Crosswell, Michigan, U.S.A., 48422 | |
| CHECKED JK | 8/6/2009 | | |
| APPROVED CLO | 8/24/1983 | TITLE | |
| PART | | AERATOR FINAL ASSEMBLY: AD-C / AD-F | |
| THIS PRINT IS PROPERTY OF CONVEYOR COMPONENTS CO., AND MAY NOT BE USED IN WHOLE OR PART WITHOUT WRITTEN PERMISSION. | | Drawing is computer generated, and print might not be to scale | |
| SIZE C | DWG NO C0160005.dwg | REV B | |
| SCALE | | | SHEET 1 OF 1 |